

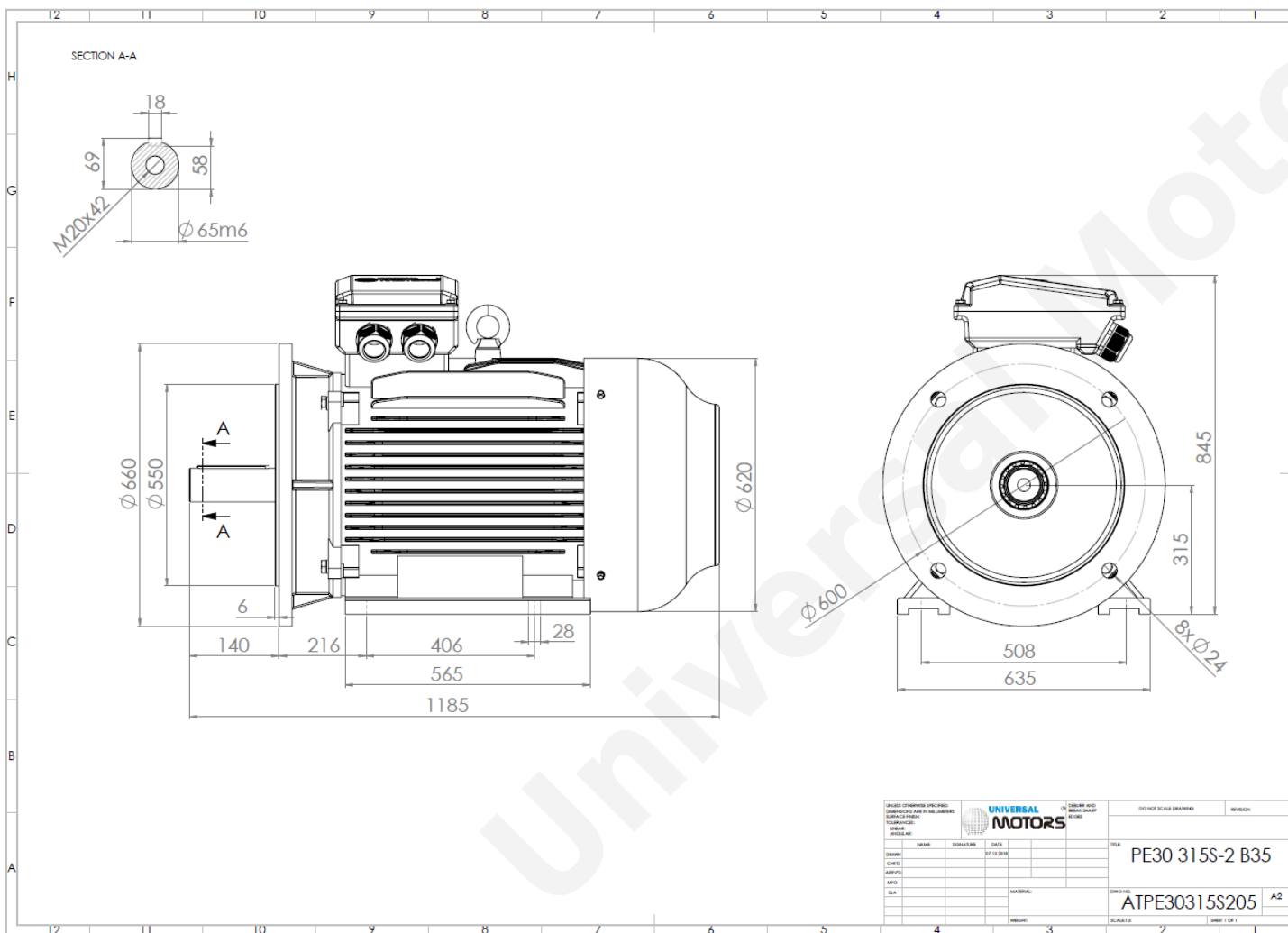

TECHNICAL DATA

Three Phase Electric Motors - Cast Iron Frame
 PE30 315 S 2 IE3
 110 kW / 150 Cv
 2980 RPM



Motor type:	PE30 315 S 2 IE3
Output:	110 kW / 150 Cv
Speed (min ⁻¹):	2980 RPM
Frequency:	50 Hz
Voltage:	400 V
Current:	185.0 A
Power factor (Cos Ø):	0.90
Poles:	2
Insulation class:	F
Temperature rise Class:	B
Efficiency 50%:	94.5 %
Efficiency 75%:	95.3 %
Efficiency 100%:	95.2 %
Torque:	352 N.m
Tstarting/Tnominal:	1.8
Istarting/Inominal:	7.1
Tmaximum/Tnominal:	2.3
Noise:	92 Db(A)
Weight:	905 Kg
Bearing DE:	6317 C3
Bearing NDE:	6317 C3

Regime - S1

Altitude - 1000m

Environment Temperature - 40°C

CONTACTS:

UNIVERSAL MOTORS Tel: +351 252 299 080
 Rua de São Brás,745 Fax: +351 252 299 089
 4480-782 VILA DO CONDE Mail: geral@universalmotors.pt

* References applied only in the UK